

ME868PIB

SMART INTERLOCK TECHNOLOGY

FLO-MAX LE PROXIMITY INTERLOCK BRACKET

INSTALLATION AND OPERATING INSTRUCTIONS

ME868-16
Flo-Max LE Adapter
(Not Included)

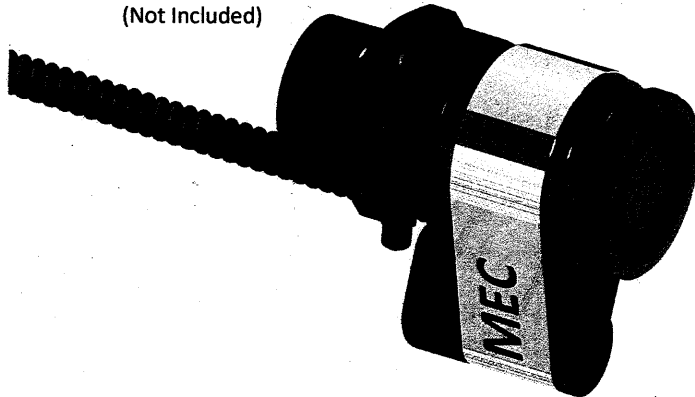

ME868PIB

ME441F8 Cap
(Not Included)

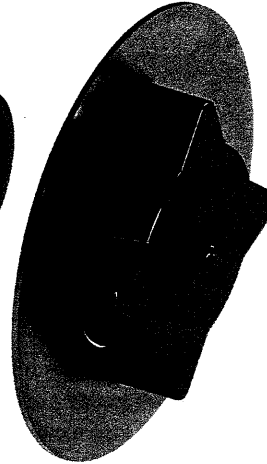

Application:

Designed to incorporate **MEC** Smart Interlock Technology with our Flo-Max LE adapter system. **MEC** Smart Interlock Technology is designed for direct connection to Allison-automatic transmissions through the "auxiliary function range inhibit" or braking systems for manual transmission vehicles. **MEC** Smart Interlock Technology prevents the vehicle from being operated while the truck is being loaded. This revolutionary system incorporates the industry's best and most durable sensor - Turck- which are backed with a lifetime product warranty.

Features:

- Molded urethane sensor body housing for durability and maximum sensor protection
- Stainless steel mounting band and hardware
- Supplied standard with **MEC** Smart Interlock Technology
 - Interlock technology features Turck® proximity switch for maximum weather resistance and security against vibration
 - Supplied with water tight conduit and necessary wiring hardware to reach 5' below deck with water tight receptacle plug
 - Optional wiring harness cable kits available in 20' or 30' lengths

Part #	Description
ME868PIB	MEC Smart Interlock Bracket Kit for ME868 Flo-Max LE Series Adapters
Accessories	
Part #	Description
MEP801PC/20	20' Smart Interlock Cable w/ Water Tight Receptacle Plug - Only
MEP801PC/30	30' Smart Interlock Cable w/ Water Tight Receptacle Plug - Only
MEP801PCK/20	Complete 20' Smart Interlock Cable Kit w/1 Relay / LED Power Indicator / Inline Fuse
MEP801PCK/30	Complete 30' Smart Interlock Cable Kit w/1 Relay / LED Power Indicator / Inline Fuse
MEP802PCK/20	Complete 20' Smart Interlock Cable Kit w/2 Relays / LED Power Indicator / Inline Fuse
MEP802PCK/30	Complete 30' Smart Interlock Cable Kit w/2 Relays / LED Power Indicator / Inline Fuse



ME868PIB

SMART INTERLOCK TECHNOLOGY FLO-MAX LE PROXIMITY INTERLOCK BRACKET INSTALLATION AND OPERATING INSTRUCTIONS

Scope

The ME868PIB Proximity Interlock Bracket is designed for use with ME868 Series Flo-Max LE Emission Acme Adapters.

Specifications

Supply Voltage: 10-30 VDC
 Max Current Draw: 200 MA (0.2A)
 Sensor Type: Normally Open
 Relay Type: Normally Open
 Fuse Rating: 1 AMP
 Temperature Limits: -20° F. to 160°F. (MEP801PIK/ MEP801PIH)
 Temperature Limits: -50°F. to 160°F. (MEP801PIKL/ MEP801PIHL)

Installation

WARNING: Failure to follow these instructions or to properly install and maintain this equipment could result in an explosion and/or fire causing property damage or personal injury or death. Marshall Excelsior Company equipment must be installed, operated and maintained in accordance with all federal, state and local codes and Marshall Excelsior instructions. The installation in most states must also comply with NFPA standards 58 and 59, and ANSI K61.1

Only personnel trained in the proper procedures, codes, standards and regulations of the LP-Gas and NH₃ industries should install, maintain, and service this equipment.

Be sure all instructions are read and understood before installation, operation and maintenance. These instructions must be passed along to the end user of the product.

CAUTION: Contact or inhalation of liquid propane, ammonia and their vapors can cause serious injury or death! NH₃ and LP-Gas must be released outdoors in the air currents that will insure dispersion to prevent exposure to people and livestock. LP-Gas must be kept far enough from any open flame or other source of ignition to prevent fire or explosion! LP-Gas is heavier than air and will not disperse or evaporate rapidly if released in still air.

CAUTION: The power supply in your system may produce energy hazards, which can cause bodily harm. To reduce the risk of electrical shock, a trained service technician must disconnect the power supply cables from the battery terminals before installation or service of the system.

NOTE: Before installing, inspect interlock assembly for shipping damage that may affect performance

1. Remove mounting hardware from bracket as shown

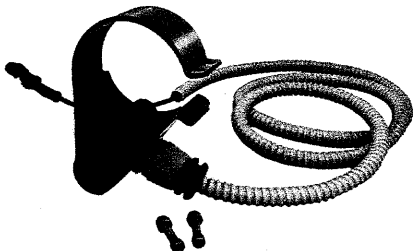

2. Spread bracket flanges over barrel of ME868 Series Flo-Max LE Low Emission Acme Adapter as shown

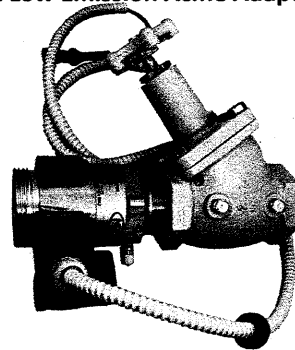

3. Tighten band around Acme adapter and install mounting hardware through flange tabs as shown.

Note: Leave mounting hardware finger tight at this point

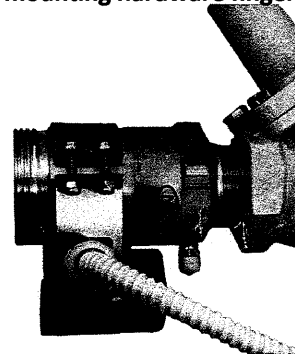

4. Install ME441F8 Acme cap with flange onto ME868 Series Acme adapter as shown and tighten using MEP120B Spanner Wrench

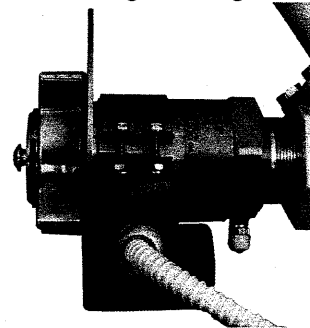

5. Slide sensor assembly forward on barrel of ME868 Series Acme adapter until face of sensor body touches back of flange on Acme cap as shown

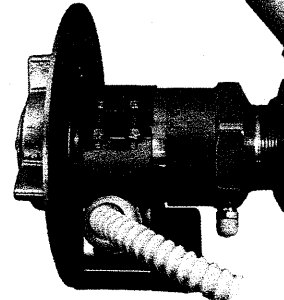

6. Ensure sensor body is positioned below ME868-16 Acme adapter as shown and tighten mounting hardware using appropriate wrench.



SMART INTERLOCK TECHNOLOGY FLO-MAX LE PROXIMITY INTERLOCK BRACKET INSTALLATION AND OPERATING INSTRUCTIONS

Route and Secure Conduit

- a. Determine where the conduit is to be routed and where it will pass through the deck or cabinet wall:
 - To pass sensor plug and conduit through deck or cabinet: drill a 1" to 1-1/16" diameter hole, route sensor cable thru hole and install grommet as shown.



- b. Secure conduit to support surface approximately every six to eight inches with suitable conduit clamp or wire tie (not provided)

3. Connect Interlock to Allison Transmission "Auxiliary Function Range Inhibit"

WARNING:

- The positive (+) supply conductor of the interlock circuit **MUST** be protected by a fuse with a maximum rating of 1 Amp, as provided in the MEC Proximity Cable Kits. **It must be replaced only with a fuse of the same rating.**
- The maximum current draw thru the MEP801PIK/L sensor is 200 MA (0.2A)
- Ground connections must be made as indicated by vehicle manufacturers instructions

- a. Connect the sensor cable plug to the mating connector on the 20' or 30' Single relay (MEP801PCK/20 or MEP801PCK/30), Dual relay (MEP802PCK/20 or MEP802PCK/30) or Universal (MEP801PC/20 or MEP801PC/30) Proximity Cable kit.
- b. Secure the connection in a protected location and route and secure all cables and wires using loom and wire ties or other suitable means
- c. Mount the sealed relay using the bracket provided, in either the engine compartment or cab, as desired. Note: when mounting in the engine compartment, keep relay away from sources of heat and orient wires so they point down.
- d. Make the electrical connections as indicated on the wiring circuit diagrams included in this manual. For final connections to the Allison "Auxiliary Function Range Inhibit" circuit, follow the manufacturers instructions provided with the Allison transmission.

NOTE: Only trained personnel that are qualified to make connections to the Allison Transmission's range inhibit function, such as Allison Transmission certified technicians, should make these connections.
- e. Test the Proximity Interlock / Range Inhibit function for proper operation by installing a hose end valve into the holster or manually depressing sensor paddle and confirming that the red LED in the relay lights up indicating the circuit has been closed, and that the Range Inhibit interlock function allows Allison Transmission to shift out of Park.

Operation

When the ME441F8 flange cap is placed onto the ME868-16 Flo-Max LE Acme Adapter the sensor is actuated closing the sensor circuit. The sensor circuit interfaces with the auxiliary function range inhibit allowing the vehicle transmission to be shifted out of the park position.

WARNING: Never operate with a leaking valve. Failure to follow these instructions could result in an explosion and/or fire causing property damage or personal injury or death.

Trouble Shooting

Problem	Possible Cause	Recommended Action
LED on relay does not light or relay does not activate	Relay not properly grounded	Mount the relay bracket to a grounded metallic surface or attach a ground strap between the relay bracket and an electrically grounded connection.
LED on relay does not light or relay does not activate	Protective over-current fuse is blown	Replace the fuse ONLY with a fuse of an identical 1 AMP rating
LED on relay does not light or relay does not activate	No power to sensor	Remove cover on sensor housing to verify green light on Turke sensor, if no light then: <ul style="list-style-type: none"> • Check fuse • Check for 12 volt with key on • Check ground wire from sensor



**SMART INTERLOCK TECHNOLOGY FLO-MAX LE PROXIMITY INTERLOCK BRACKET
INSTALLATION AND OPERATING INSTRUCTIONS**

Trouble Shooting Continued...		
Problem	Possible Cause	Recommended Action
LED on relay does not light or relay does not activate	No signal from sensor	Remove cover on sensor housing with sensor paddle pushed in verify change light on Turke sensor. If no light then: <ul style="list-style-type: none"> • Sensor needs to be replaced • Paddle needs replaced
LED on relay does not light or relay does not activate	Wiring—Incorrect or damaged	<ul style="list-style-type: none"> • Check for 12 volts at pin 1 of sensor plug with key on • Check for 12 volts at pin 2 with paddle depressed and key on • Check for 0 ohms between pin 3 and (-) negative terminal of battery • Check for 0 ohms between relay black wire and (-) negative terminal of battery • Check for any loose crimps or damaged wires • Check for corrosion at all wiring connection points
LED on relay does not light or relay does not activate	Faulty delay	Replace delay
LED on, relay is on but truck will not shift out of park	Faulty Relay	Replace relay
LED on, relay is on but truck will not shift out of park	Wiring incorrect or damaged	<ul style="list-style-type: none"> • Verify connections to and from the TCM of the transmission • Check for any loose crimps or damaged wires. • Check for corrosion at all wiring connections
Connections test OK but interlock still does not function properly	Damaged or defective proximity sensor, sensor cable or sensor connector pins	Disconnect sensor connector and connect test jumper in its place. If interlock functions properly with test jumper but not with sensor, sensor must be repaired or replaced.

Maintenance

To ensure proper operation, perform the following maintenance:

1. Check that the holster paddle moves freely before each use. Repair or replace interlock if it is not functioning properly.
2. Check that all fasteners are tight at least monthly. Tighten any that are found to be loose.
3. Check sensor relay for proper operation as indicated by red LED light on relay.



MEP801PIK WIRING DIAGRAM

PROXIMITY INTERLOCK KIT

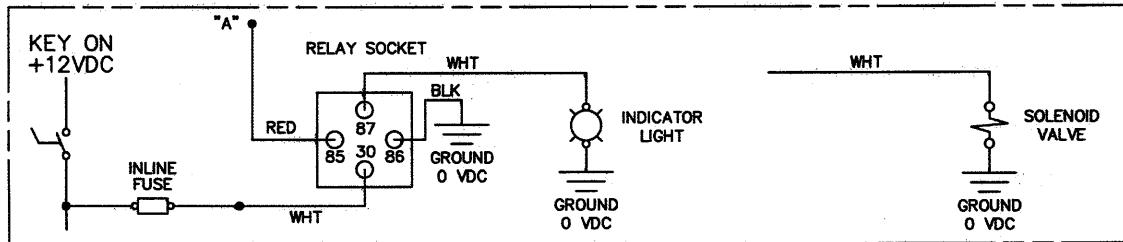
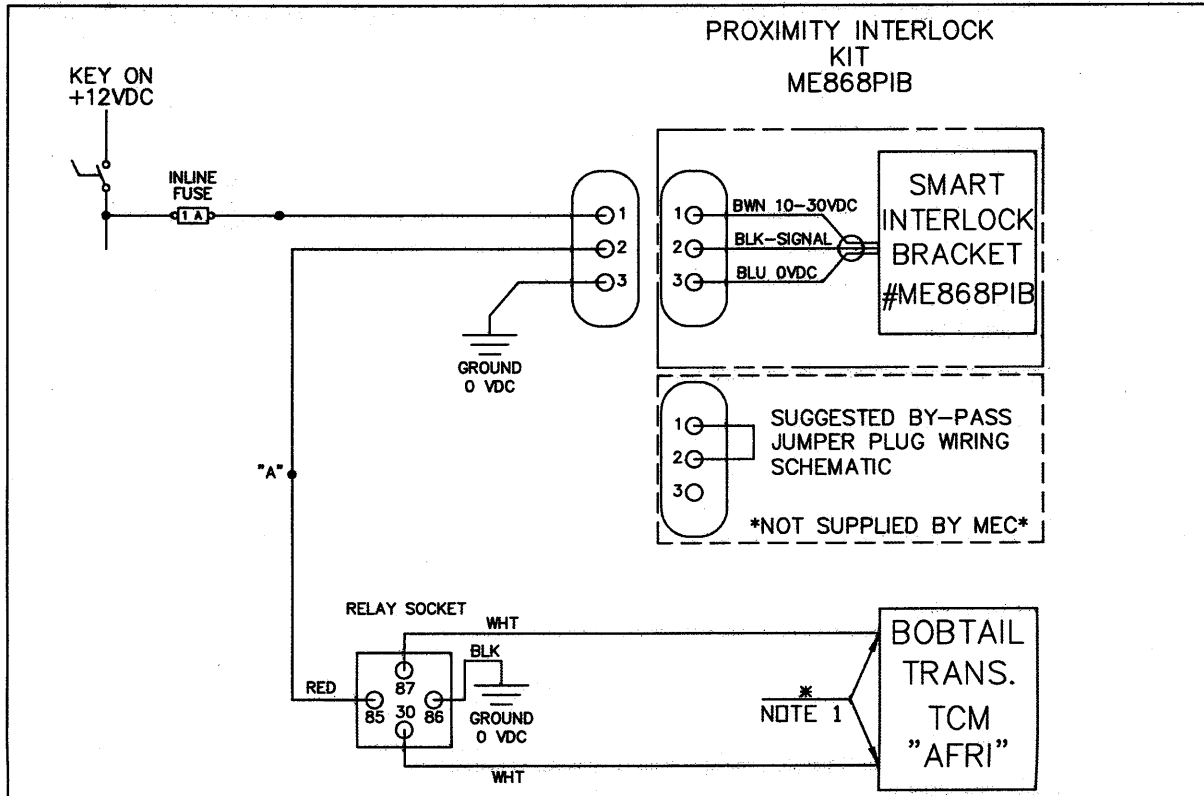

NOTES:

1. CONNECT TO TRANSMISSION PER THE "AUXILIARY FUNCTION RANGE INHIBIT CIRCUIT" OF THE TRANSMISSION TCM.

WARNING - MAX CURRENT DRAW THRU THE ME868PIB SENSOR IS 200ma.

MARSHALL EXCELSIOR CO.

DRAWN AZ	NAME ME868PIB WIRING DIAGRAM PROXIMITY INTERLOCK KIT	PAGE 1-1	DRAWING NO. ME868PIB-WD
DATE 1/22/09			



MEP801PCK WIRING DIAGRAM

SINGLE RELAY PROXIMITY CABLE KIT

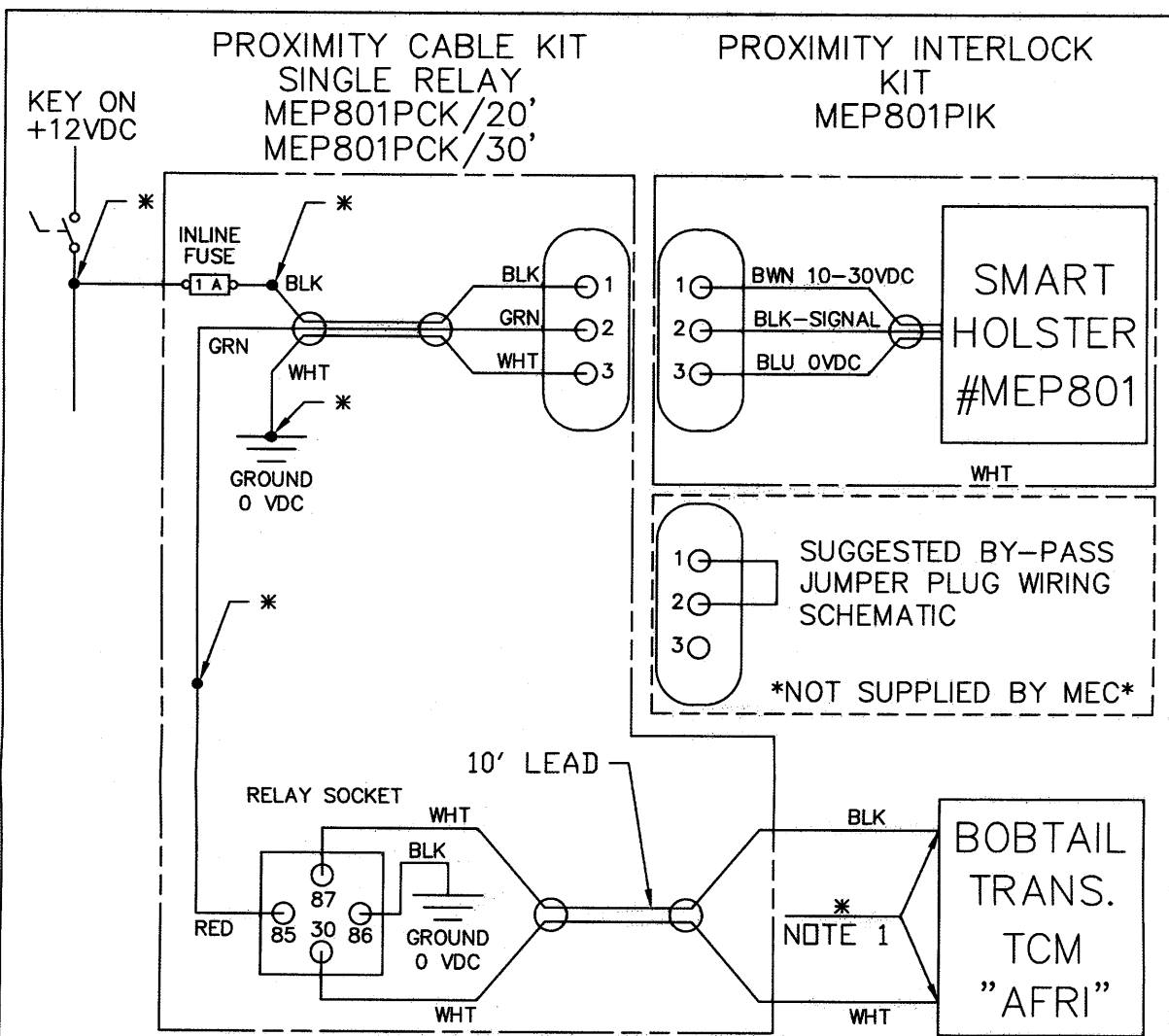

NOTES:

1. CONNECT TO TRANSMISSION PER THE "AUXILIARY FUNCTION RANGE INHIBIT CIRCUIT" OF THE TRANSMISSION TCM.
- * CUSTOMER CONNECTIONS.

MARSHALL EXCELSIOR CO.

DRAWN AZ	NAME MEP801PCK WIRING DIAGRAM	PAGE 1-1	DRAWING NO. MEP801PCK-WD
DATE 1/22/09	SINGLE RELAY PROXIMITY CABLE KIT		



MEP801PC WIRING DIAGRAM

PROXIMITY CABLE KIT

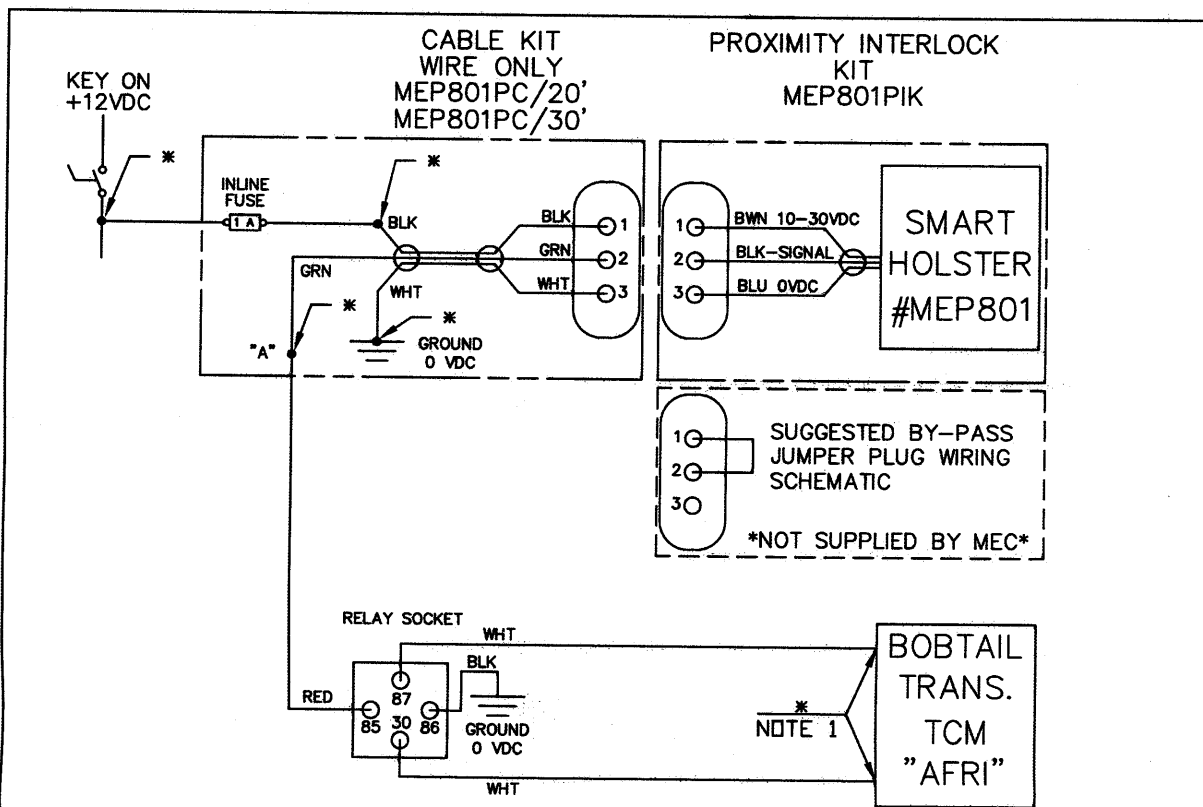

MEC SUGGESTED WIRING

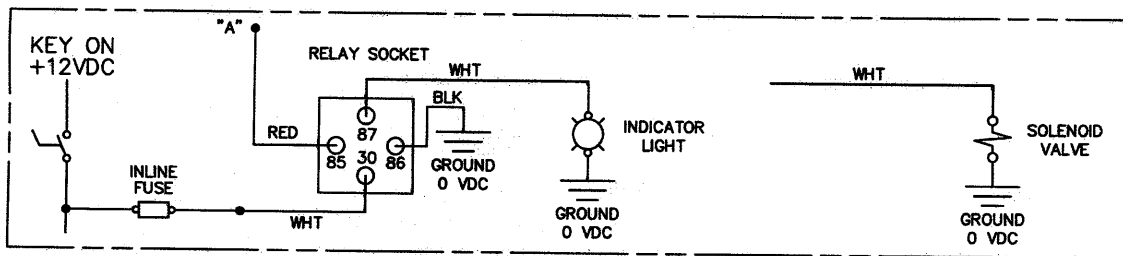

OPTIONAL WIRING

NOTES:

1. CONNECT TO TRANSMISSION PER THE "AUXILIARY FUNCTION RANGE INHIBIT CIRCUIT" OF THE TRANSMISSION TCM.

WARNING - MAX CURRENT DRAW THRU THE MEP801PIK SENSOR IS 200ma.

* CUSTOMER CONNECTIONS.

MARSHALL EXCELSIOR CO.

DRAWN az	NAME MEP801PC WIRING DIAGRAM	PAGE 1-1	DRAWING NO. MEP801PC-WD
DATE 1/22/09	PROXIMITY CABLE KIT		

