

The **Smith Meter® Model T-20 Meter** is a 3", single case, angle type, rotary vane, positive displacement meter. Applications include: blending, batching, dispensing, inventory control and custody transfer of oils, solvents, chemicals, paints, fats, and fertilizers.

Features

- **Superior Accuracy** – The Smith Meter® rotary vane meter principle minimizes pressure drop across the measuring chamber which reduces flow through meter clearances to maximize accuracy.
- **Low Pressure Drop** – Streamlined flow path provides low pressure drop.
- **Positive and Accurate Registration** – High torque drive calibrator with adjustment in 0.05% increments ensures accurate registration.
- **Long Service Life** – Low friction ball bearings, fixed cam type timing, and rugged construction give sustained accuracy and long service life.

Operating Specifications

Maximum Flow Rate

| | USGPM | l/min |
|-----------------------------|-------|-------|
| T-20 Continuous Rating | 200 | 750 |
| T-20 Intermittent Rating+ | 240 | 900 |
| T-20 (All Iron Trim) Rating | 150 | 570 |

+ Intermittent rating applies to service on clean, refined products where continuous operation is not required (e.g., truck loading, rail loading, and other batching applications).

Minimum Flow Rate – Typical Performance

| Linearity* | Units | Viscosity (mPa·s) | | | | | |
|------------|-------|-------------------|----|----|-----|------|------|
| | | 0.5 | 1 | 5 | 20 | 100 | 400 |
| +/-0.15% | USGPM | 40 | 25 | 10 | 2.5 | 0.50 | 0.12 |
| | l/min | 150 | 95 | 38 | 9.5 | 1.90 | 0.45 |
| +/-0.25% | USGPM | 30 | 18 | 8 | 2.0 | 0.40 | 0.10 |
| | l/min | 113 | 68 | 30 | 7.6 | 1.50 | 0.38 |
| +/-0.50% | USGPM | 20 | 12 | 5 | 1.2 | 0.25 | 0.06 |
| | l/min | 75 | 45 | 19 | 4.5 | 0.90 | 0.22 |

* Based on a maximum flow rate of 200 USGPM (750 l/min).

Repeatability

±0.02%



Viscosity

Standard: 400 mPa·s* (2,000 SSU) maximum.

Optional: 2 Pa·s (10,000 SSU) maximum – specify “High Viscosity Meter Clearances.”

Over 2 Pa·s: Specify “High Viscosity Meter Clearances” and derate maximum flow rate in direct proportion to viscosity over 2 Pa·s (e.g., at 4 Pa·s, derate maximum flow rate to 50% of normal continuous rating – 100 USGPM).

* 1,000 mPa·s = 1,000 cP = 1 Pa·s.

Temperature

Standard: -20°F to 150°F (-29°C to 65°C).

Optional: -20°F to 200°F (-29°C to 93°C) – specify “High Temperature Meter Clearances” or “All Iron Trim.”

Other Temperatures: Consult factory.

Maximum Working Pressure

Standard: 150 psig (1,034 kPa) up to 200°F (93°C).

Meter Gearing

One U.S. Gallon or 1 dekaliter per revolution of meter calibrator output shaft.

Pressure Drop (ΔP)

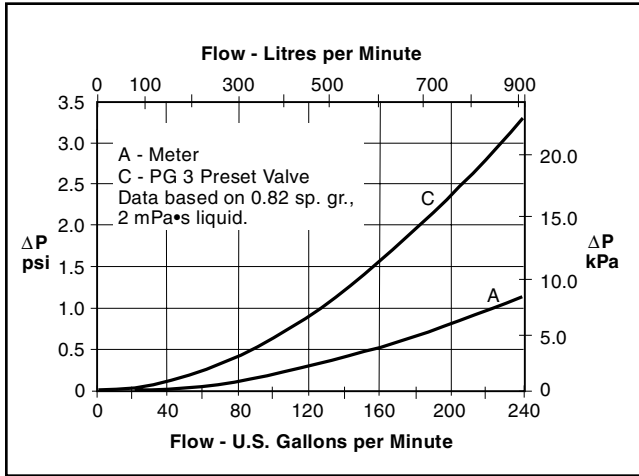

Materials of Construction

| Meter | Housing | Internals | Seals |
|------------------------------|-----------|--------------------------------------------------|----------------------------------------------------------------------------------------------|
| T-20 | Cast Iron | Iron, Steel, Stainless Steel, Aluminum*, Bronze* | Cover O-Ring Std. - Buna-N Opt'l. - Viton Packing Gland Std. - Buna Opt'l. - Viton or Teflon |
| Valve: SPG-3 Preset Valve | Aluminum | Steel, Iron, Aluminum | Std. - Buna N, Opt'l. - Viton |

* All iron trim (no aluminum or bronze) optional.

Meter End Connections

Smith square flanges with 3" Female NPT threaded companion flanges.

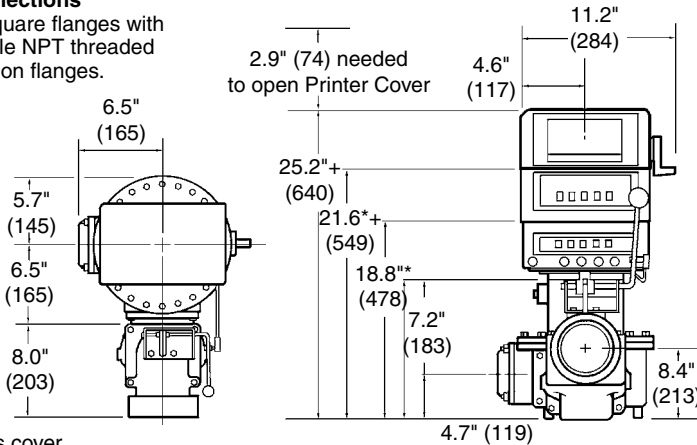

*Includes cover.

+Deduct 3.7" (94) if Present Counter is not required.

Weights

| | lb. | kg. |
|------------------|-----|-----|
| Meter | 82 | 37 |
| Meter/LNC+ | 97 | 44 |
| Preset Package+* | 123 | 56 |

+ Add 10 lb. (4.5 kg) if ticket printer is required.

*Includes Meter, LNC, Preset Counter and valve.

Inlet/Outlet Positions

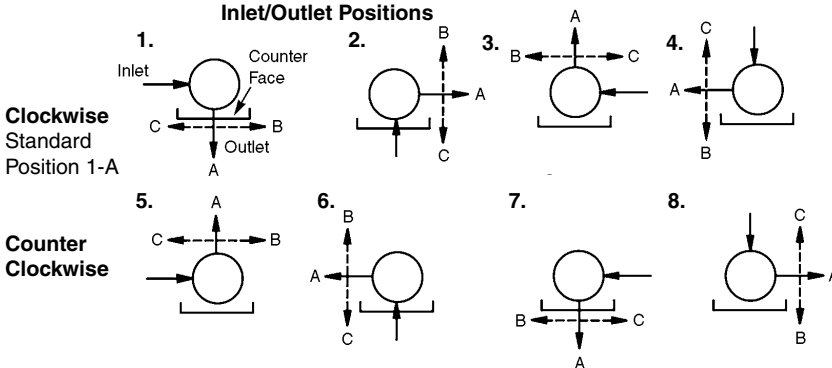

Note: A, B, C denotes orientation of valve outlet if used.

Note: Dimensions – Inches to the nearest tenth (millimetres to the nearest whole mm), each independently dimensioned from respective engineering drawings.

Top View

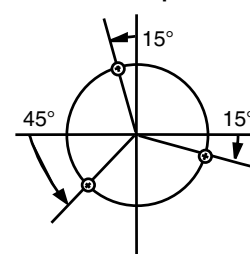

Meter Anchor Bolt Holes
3-3/8" – 16 Tapped Holes equally spaced on a 8.125" (206) dia. bolt circle.

Ordering Information

| | |
|----------------------------------|-----------------------------------------------------------------------------------------------------------------------------------------------|
| Application | Batching, Loading, Blending, Inventory, Process Control, etc. |
| Operating Conditions | Liquid – Name and Sp. Gr., Flow Range*, Temp. Range*, Viscosity Range*, Maximum Working Pressure. <i>*Specify: minimum/normal/maximum.</i> |
| Seals | Meter: Buna*, Viton or Teflon. Valve: Buna*, Viton. <i>+Standard seals supplied unless optional material specified.</i> |
| Units of Registration | Gallons, Liters, Pounds, Kilograms. |
| Inlet/Outlet Position | Position 1-A is standard and will be supplied unless another position (e.g., 2-C) is specified. |
| Options & Accessories | As required. |

Accessories

Mechanical Preset Valves

3" offset type, cast aluminum, NPT outlet.

Automatic Temperature Compensation

Model ATC – Factory set for a given product.

Model ATG – Field-adjustable for different products.

Counters

200 Series – Accumulative, nine digit, non-reset type.

600 Series – Five large digit reset, eight small digit non-reset.

Printer

Seven digit accumulative.

Optional six digit zero start.

Preset Counter

300C Series – Four digit (five digit optional) mechanical push-button preset with micro switch package for valve or pump control.

Pulse Transmitters

Type E – SPDT Mercury Wetted Switch.

LNC Pulse Transmitter (adapts to 600 Series Counters).

Low-Resolution – 1 or 10 pulses¹.

High-Resolution (HR) – 50 or 100 pulses¹.

PST – Dual-channel, high-resolution, security pulse generator.

UPT – Universal Pulse Transmitter – High resolution dual pulse quadrature output in a weather-tight explosion-proof enclosure (up to 1,000 pulses/rev.).

Flow Rate Indicator

Direct mount mechanical.

Remote electronic.

Remote Registration

Electro-mechanical counters.

Electronic totalizers.

¹ Per revolution of LNC right-hand wheel.

Revisions included in SS01002 Issue/Rev. 0.6 (2/08):
Page 2: 3" Y Type Strainer Removed.
Page 3: Removed Strainer from the Accessories.

The specifications contained herein are subject to change without notice and any user of said specifications should verify from the manufacturer that the specifications are currently in effect. Otherwise, the manufacturer assumes no responsibility for the use of specifications which may have been changed and are no longer in effect.

Headquarters:

500 North Sam Houston Parkway West, Suite 100 Houston, TX 77067 USA, Phone: +1 (281) 260-2190, Fax: +1 (281) 260-2191

Gas Measurement Products:

Houston, TX USA +1 (281) 260-2190
Thetford, England +44 (1842) 82-2900
Kongsberg, Norway +47 (32) 286-700
Buenos Aires, Argentina +54 (11) 4312-4736

Integrated Measurement Systems:

Corpus Christi, TX USA +1 (361) 289-3400
Kongsberg, Norway +47 (32) 286-700
San Juan, Puerto Rico +1809 (787) 274-3760
United Arab Emirates, Dubai +971 (4) 331-3646

Liquid Measurement Products:

Erie, PA USA +1 (814) 898-5000
Los Angeles, CA USA +1 (310) 328-1236
Slough, England +44 (1753) 57-1515
Ellerbek, Germany +49 (4101) 304-0
Barcelona, Spain +34 (93) 201-0989
Moscow, Russia +7 (495) 564-8705
Melbourne, Australia +61(3) 9807-2818

Beijing, China +86 (10) 6500-2251
Singapore +65 6861-3011
Chennai, India +91 (44) 450-4400

Visit our website at www.fmctechnologies.com/measurementsolutions